

## UNIT WELL 15 – VOLATILE ORGANIC COMPOUND (VOC) MITIGATION

Madison Water Utility  
Madison, Wisconsin

Black & Veatch Corporation  
B&V Project 169092.0800  
B&V File 41.0800

Black & Veatch Corporation  
225 E. Mason Street, Suite 801  
Milwaukee, Wisconsin 53202

*February 8, 2011*

DRAFT



## TABLE OF CONTENTS

1.	Background .....	1
2.	Description of Unit Well No. 15 .....	1
3.	Facility Condition Assessment .....	1
4.	Water Quality.....	2
5.	Regulatory Considerations .....	2
5.1	Best Availability Technology.....	2
5.2	Alternative Treatment Technology .....	3
5.3	Emission Thresholds - Aeration Technology.....	3
5.4	Future Regulatory Action - Tetrachloroethylene and Trichloroethylene .....	3
6.	Site Limitations .....	4
7.	Overview of Treatment Options.....	4
8.	Conventional Air Strippers.....	4
8.1	Equipment Description and Design Parameters .....	4
8.2	Building and Site Layout.....	5
8.3	Operational Impacts .....	6
8.3.1	Chemical Treatment System.....	6
8.3.2	Well Pump Capacity .....	6
8.4	Off-Gas Treatment .....	7
9.	Low Profile Aeration .....	8
9.1	Equipment Description and Design Parameters .....	8
9.2	Building and Site Layout.....	9
9.3	Operational Impacts .....	9
9.3.1	Chemical Treatment System.....	9
9.3.2	Well Pump Capacity .....	9
9.4	Off-Gas Treatment .....	9
10.	Granular Activated Carbon Adsorption .....	9
11.	Conceptual Opinion of Probable Project and Life Cycle Costs.....	10
11.1	Conventional Air Strippers.....	10
11.2	Low Profile Aeration .....	11
11.3	20-Year Life Cycle Costs.....	12
12.	Evaluation Summary .....	12

TABLES

Table 1	Selected Raw Water Quality Parameters .....	2
Table 2	Emission Thresholds for Sources of Specific Hazardous Air Contaminants.....	3
Table 3	Forced Draft Aeration Unit Design Parameters.....	5
Table 4	Polyphosphate System Design Parameters.....	6
Table 5	Calculated Aerator Emission Volumes .....	7
Table 6	Low profile Aeration Unit Design Parameters .....	8
Table 7	GAC Adsorption Unit Design Parameters .....	10
Table 8	Conceptual Opinion of Probable Project Costs Conventional Air Strippers.....	11
Table 9	Operation and Maintenance Cost Conventional Air Strippers.....	11
Table 10	Conceptual Opinion of Probable Project Costs Low Profile Aeration System .....	12
Table 11	Operation and Maintenance Cost Low Profile Aeration System .....	12
Table 12	20-Year Life Cycle Cost Estimates Forced Draft and Low Profile Aeration Systems .....	12

FIGURES

	<u>Following Page</u>	
Figure 1	Unit Well No. 15 Location Map..... 1	
Figure 2	Unit Well No. 15 Site Plan..... 4	
Figure 3	Conventional Air Stripper - Building Plan & Section .....	5
Figure 4	Conventional Air Stripper - Site Plan.....	5
Figure 5	Polyphosphate Storage and Feed System.....	6
Figure 6	Low Profile Air Stripper - Building Plan & Section.....	9
Figure 7	Low Profile Air Stripper - Site Plan.....	9
Figure 8	Granular Activated Carbon (GAC) Contractors.....	10

APPENDICES

Appendix A	Equipment Information
Appendix B	Pump Characteristic Curves
Appendix C	Conceptual Opinion of Probable Construction Costs

## 1. BACKGROUND

The Madison Water Utility (MWU) is developing a comprehensive plan to provide a reliable supply of high quality water cost effectively to the City's Zone 6 - East Service Area. The Zone 6 - East Service Area is served by five wells including Unit Well Nos. 7, 8, 11, 15, and 29.

This memorandum addresses water quality issues at Unit Well No. 15. Unit Well No. 15 is exhibiting concentrations of the regulated Volatile Organic Compound (VOC), tetrachloroethylene (PCE), that are steadily approaching the Maximum Contaminant Level (MCL) of 5 micrograms per liter ( $\mu\text{g/L}$ ). In addition, detectable levels of trichloroethylene (TCE) are present in the water supply from Unit Well No. 15.

The primary objective of this memorandum is to evaluate available treatment options for the removal of the VOCs present in the water from Unit Well No. 15 and to make recommendations to the MWU as to the most cost-effective treatment approach for Unit Well No. 15. This memorandum also provides a facility condition assessment for Unit Well No. 15.

## 2. DESCRIPTION OF UNIT WELL NO. 15

Unit Well No. 15 is located in a commercial setting east of the Madison Area Technical College along Highway 151, as shown in Figure 1, an aerial photograph of the Well No. 15 site and surrounding area.

Unit Well No. 15, which is housed within a masonry block/brick building, has a production capacity of 2,200 gallons per minute (gpm). The well is operated continuously at its rated capacity. Chlorine and fluoride (hydrofluosilicic acid) are fed to the well pump discharge which is conveyed to a below-grade 0.15 MGD cast-in-place concrete reservoir. A constant speed vertical diffusion vane pumping unit conveys the water from the reservoir directly to the distribution system.

## 3. FACILITY CONDITION ASSESSMENT

A comprehensive facility condition assessment of water supply, treatment, and distribution facilities was conducted in 2005. The MWU's Infrastructure Management Plan, dated November 2005, presents the results of the condition assessment and recommendations for facility improvements. In general, Unit Well No. 15 was in good condition. Recommended improvements included the replacement of the asphalt drive and parking lot and replacement of the access doors.

A facility inspection was conducted in June 2010. Construction of a new asphalt drive and parking lot was completed. The building access doors should be replaced as recommended in the 2005 Infrastructure Management Plan. The facility remains in good condition and no additional facility improvements were identified.

169092-2000-GENUP-C-T0001CV3L

BFIBORD  
FBFIBORD

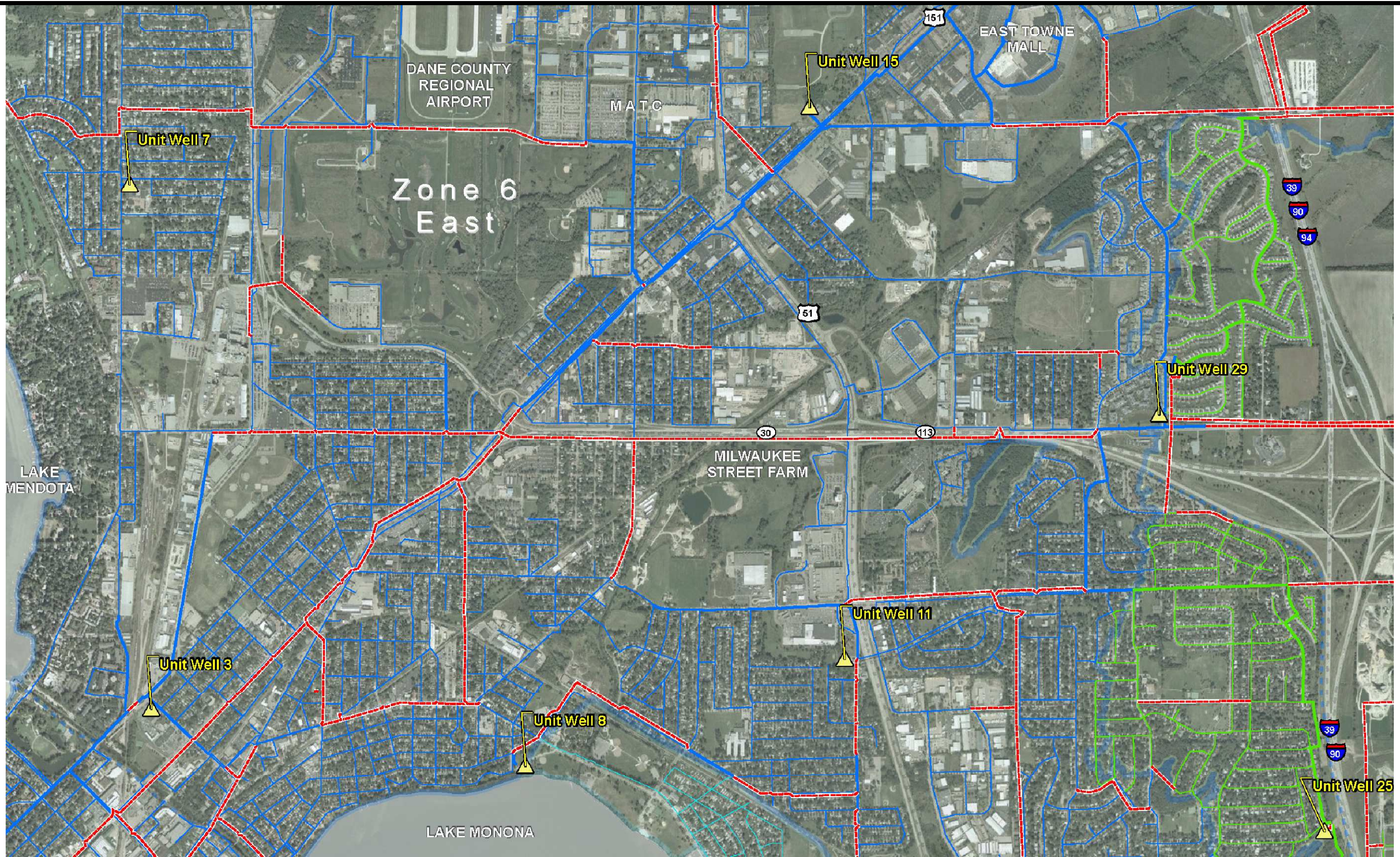

MADISON, WISCONSIN  
EAST SIDE WATER SUPPLY PLANNING  
& PROJECT DEVELOPMENT

UNIT WELL NO. 15  
LOCATION MAP

FIGURE 1

## 4. WATER QUALITY

In general, the water supply from Unit Well No. 15 is of good quality. Parameters of concern, and their associated concentration ranges for the period of 2008 – 2010, are presented in Table 1.

**Table 1. Selected Raw Water Quality Parameters**

Parameter	Concentration Range	Maximum Contaminant Level
Tetrachloroethylene (PCE)	3.1 – 3.9 µg/L	5 µg/L
Trichloroethylene (TCE)	0.33 – 0.41 µg/L	5 µg/L
Total Hardness	406 – 433 mg/L	-
Iron	0.01 – 0.04 mg/L	0.3 mg/L (Secondary MCL)
Manganese	0.0048 – 0.0128 mg/L	0.05 mg/L (Secondary MCL)

The concentration of PCE is steadily approaching the MCL of 5 µg/L and TCE is consistently detected in the supply. Operational and/or physical modifications to Unit Well No. 15 are required to lower the PCE and TCE concentrations to levels that are consistently below the respective MCLs.

The inorganic parameters presented in Table 1, including hardness, iron, and manganese, are of significance because of their potential to impact the operation and maintenance of the treatment system by causing deposition on the media and internal structures of the treatment units. The fouling/plating potential can be reduced with the application of a phosphate-based sequestering agent that will minimize deposition on the media of the selected treatment system. However, we understand that the addition of a phosphate based sequestering agent may not be favorable with the public. If a sequestering agent is not applied upstream of the treatment system, the frequency in which the media requires cleaning will increase.

## 5. REGULATORY CONSIDERATIONS

### 5.1 Best Available Technology

The U.S. Environmental Protection Agency (EPA) has designated Packed Tower Aeration and Granular Activated Carbon adsorption as the Best Available Technology (BAT) for the removal of VOCs from water supplies. Other forms of aeration have been developed since the BAT designation of the early 1990s. If alternate aeration technologies satisfy established regulatory criteria, they can be considered suitable for the removal of VOCs from drinking water supplies.

Chapter NR 809 (Safe Drinking Water) of the Wisconsin Department of Natural Resources (DNR) regulations identifies central treatment using packed tower aeration and granular activated carbon as the BAT available for achieving compliance with the MCLs for VOCs.

Chapter NR 811, *Requirements for the Operation and Design of Community Water Systems*, addresses organics removal in NR 811.48. The requirements for Packed Tower Aerators are presented in NR 811.48 (1). Of particular significance is the requirement that states “Unless waived by the department, the processes shall be designed to remove a minimum of 99 percent of the contaminant in question”. Requirements for the tower, packing, and blowers are specified in this section of the regulation.

The requirements for Granular Activated Carbon Filters are presented in NR 811.48 (2). In addition to specifying a maximum filtration rate of 6 gallons per minute per square foot for GAC pressure filters, the regulation requires the use of virgin GAC and stipulates design features of the carbon adsorbers.

### **5.2 Alternative Treatment Technology**

NR 809.24 (3) states that “A public water system owner or operator may use an alternative treatment if it is demonstrated to the department, using pilot studies or other means, that the alternative treatment is sufficient to achieve compliance with the MCLs”. It is under this section of the regulations that the DNR could consider the use of low profile aeration units for the removal of the VOCs in Unit Well No. 15.

### **5.3 Emission Thresholds – Aeration Technology**

Chapter NR 445, *Control of Hazardous Pollutants*, applies to all stationary air contaminant sources which may emit hazardous contaminants. Table A of NR 445.07 specifies the emission thresholds, standards and control requirements for all sources of hazardous air contaminants. Presented in Table 2 are the specific requirements that pertain to emissions from aeration units removing PCE and TCE from drinking water supplies.

**Table 2. Emission Thresholds for Sources of Specific Hazardous Air Contaminants**

<b>Contaminant</b>	<b>Threshold</b>	<b>Time Period</b>
PCE	9.11 pounds/hour	24 hour average
	301 pounds/year	Annual
TCE	14.4 pounds/hour	24 hour average
	888 pounds/year	Annual

If the emissions from the aeration units installed at Unit Well No. 15 exceed the thresholds specified in Table 2, vapor phase treatment would be required to comply with the threshold values. This will be addressed in detail in the subsequent sections dealing with forced draft aeration and low profile aeration.

### **5.4 Future Regulatory Action – Tetrachloroethylene and Trichloroethylene**

As part of a regulatory review required by the Safe Drinking Water Act, EPA has indicated its intention to revise the MCLs for PCE and TCE. Improvements in analytical capability, widespread occurrence in US groundwaters, and health effects data that indicates both contaminants are carcinogens, are the factors influencing EPA's decision.

It is expected that in 2012, EPA will propose an MCL of 1.0 µg/L for both PCE and TCE. The revised MCLs would likely take effect in either 2014 or 2015. As such, the treatment units designed for Unit Well No. 15 should include the flexibility to achieve removal efficiencies that would facilitate compliance with the revised MCLs with minimal equipment modifications.

## 6. SITE LIMITATIONS

Unit Well No. 15 is located on a parcel of land that is approximately 110 feet in length and 60 feet in width (0.15 acres). The location of the well house and reservoir, standby engine generator and the parking area are depicted in Figure 2.

Each treatment option will require additional property to be purchased to accommodate the treatment building. Space requirements/limitations will be addressed in detail in the subsequent sections on treatment options.

## 7. OVERVIEW OF TREATMENT OPTIONS

As previously mentioned, regulatory authorities recognize forced draft aeration (such as packed tower aerators) and GAC adsorption as accepted treatment technologies for the removal of VOCs from water supplies. As such, both of these options have been considered for mitigation of the VOCs present in Unit Well No. 15.

Low profile aeration units have been demonstrated to effectively remove VOCs from water supplies. Because these units feature a compact footprint, have a lower vertical profile, and offer relative ease of maintenance, they have also been considered for treatment at Unit Well No. 15.

The following sections of this memorandum provide detailed information about conventional air strippers (forced draft aeration units), low profile aeration units, and GAC adsorbers designed specifically for Unit Well No. 15. Conceptual cost estimates (capital, operation and maintenance, and 20 year life cycle costs) have been developed for each treatment option.

## 8. CONVENTIONAL AIR STRIPPERS

### 8.1 *Equipment Description and Design Parameters*

Equipment drawings and budgetary equipment cost information was obtained for forced draft aeration units from an equipment vendor, WesTech, based upon the requirements to treat a flow of 2,200 gpm and achieve VOC removal efficiency of 99 percent. Given the current level of VOCs in the water from Unit Well No. 15, this would yield PCE and TCE concentrations below 0.04 µg/L in the aeration unit effluent.

The information obtained from the equipment manufacturer is presented in Appendix A.

The aeration unit features an aluminum aerator housing shell with a removable bolted side panel designed for access to the aerator internals and to allow for cleaning/replacement of the Triapak media. The tower has a dedicated and standby blower with an aluminum hooded screen intake.

Triapak media is typically plastic or ceramic media that is designed to optimize the transfer of dissolved contaminants from the water column into the air stream that is forced through the aeration unit. It features a very significant amount of surface area to facilitate the transfer function. The depth of the Triapak media is a function of the amount of contaminant removal



169092-2000-GENUP-C-T0001CW54

BFIGBORD  
FBFIGBORD

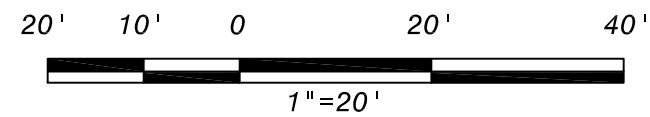

MADISON, WISCONSIN  
 EAST SIDE WATER SUPPLY PLANNING  
 & PROJECT DEVELOPMENT

UNIT WELL NO. 15  
 SITE PLAN

FIGURE 2

required. The higher the desired level of removal, the greater the depth of Triapak media necessary to affect the transfer function.

The forced draft aeration unit conceptual design for Unit Well No. 15 does not provide for redundant aeration units. It is anticipated that media cleaning and routine maintenance activities would not occur during peak demand periods.

Table 3 summarizes the key design elements of the WesTech forced draft aeration unit at a removal efficiency level of 99 percent.

**Table 3. Forced Draft Aeration Unit Design Parameters**

Parameter	
No. of Aeration Units	1
VOC Removal Efficiency	99 percent
Capacity of Aeration Unit	2,200 gpm
Hydraulic Loading Rate	24.7 gpm/sf
Air-to-Water Ratio	30:1
Dimensions of Aeration Unit	10 ft (l) x 13 ft (w) x 20 - 23 ft (h)
Media	1/2 – 1 inch Triapak
Media Height	10 – 15 feet
Forced Draft Blower Rating	6,075 scfm
Weight (filled with water)	15,000 lbs
Expected Media Cleaning Frequency	every 3-6 months

Because of the elevated hardness concentration in the water from Unit Well No. 15, provisions should be made for periodic cleaning of the Triapak media and the aerator internals. This typically consists of circulating a dilute citric acid solution throughout the media. Provision must be made for handling and disposal of the spent acid solution.

Based upon information provided by the equipment vendor, it is expected that the forced draft aeration unit will require chemical cleaning at a frequency of two to four times each year. The cleaning cycle can generally be completed in one day. Given the importance of Unit Well No. 15 to the City's Zone 6 - East Service Area, it must be determined if the well can be removed from service when cleaning is required. If it is determined that the cleaning frequency would be operationally disruptive, a redundant aeration unit could be installed to maintain constant flow from the facility.

## **8.2 Building and Site Layout**

Although the air stripper could be located outdoors above the reservoir, we understand MWU's preference is to locate the equipment in a building. A conceptual building plan and section is depicted in Figure 3. A conceptual site plan is depicted in Figure 4. As indicated on the site plan, additional property would need to be acquired to accommodate the building.

## **8.3 Operational Impacts**

The installation of a conventional air stripper at the Unit Well No. 15 site would require an additional chemical treatment system to reduce the frequency of media cleaning activities. Also,

169092-2000-GENUP-C-T0001DLBC

BFIGBORD  
BFIGBORD

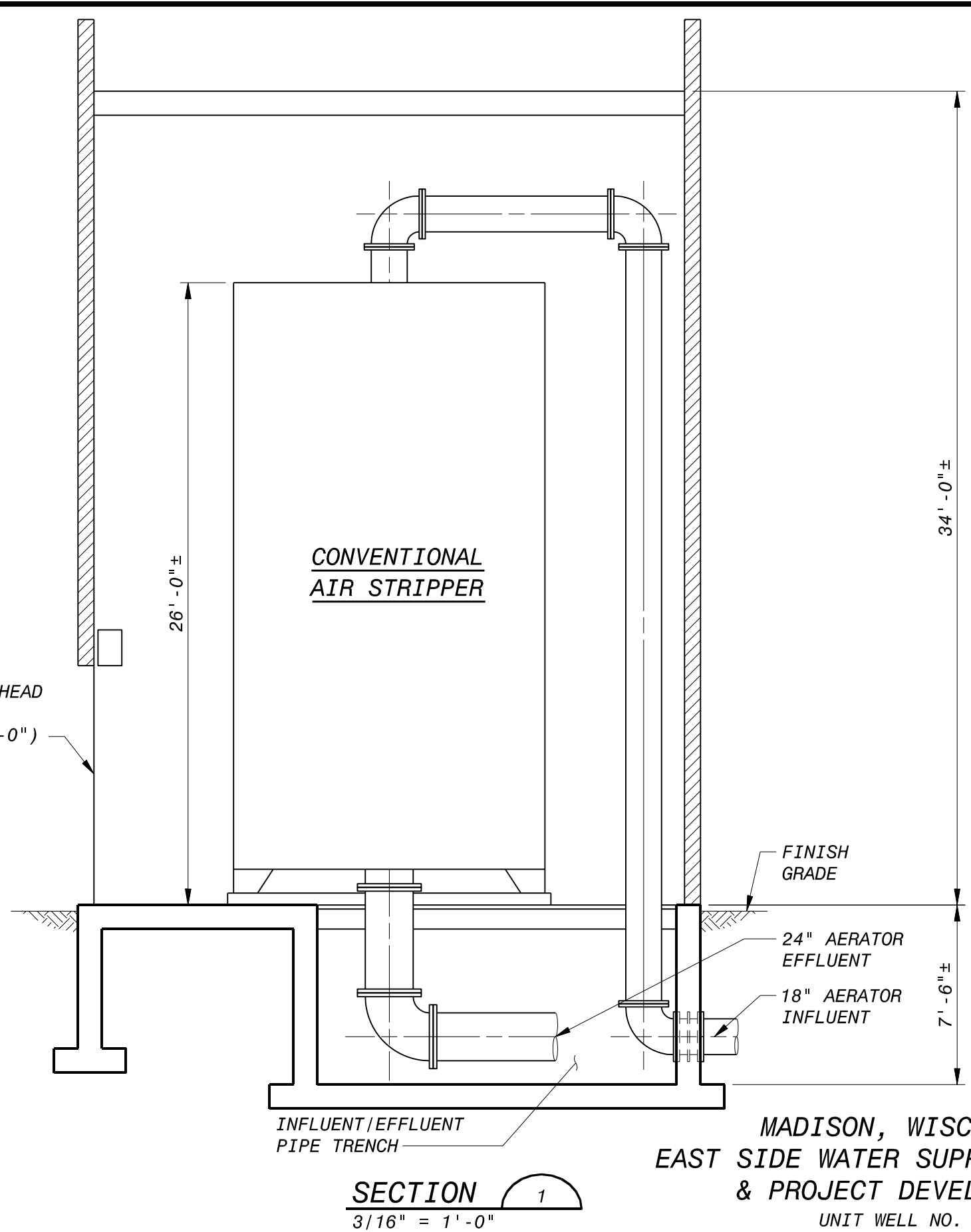
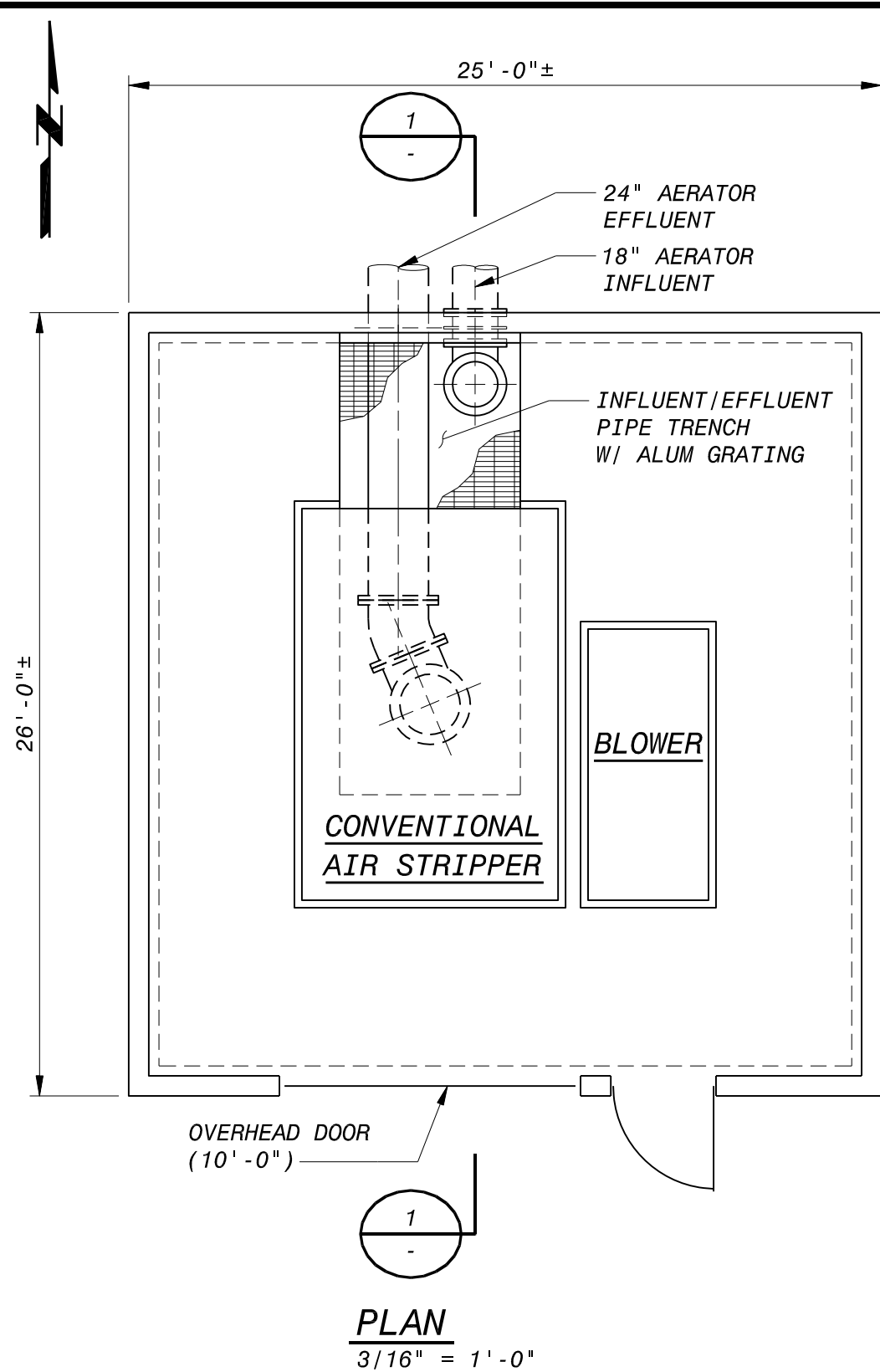

MADISON, WISCONSIN  
 EAST SIDE WATER SUPPLY PLANNING  
 & PROJECT DEVELOPMENT  
 UNIT WELL NO. 15  
 CONVENTIONAL AIR STRIPPER BUILDING  
 PLAN & SECTION

FIGURE 3

169092-2000-WTCN-C-T0001DLLP

BFIBGORD  
FBFIBGORD

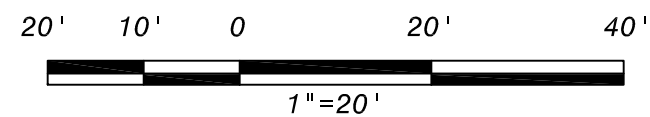

MADISON, WISCONSIN  
 EAST SIDE WATER SUPPLY PLANNING  
 & PROJECT DEVELOPMENT

UNIT WELL NO. 15  
 CONVENTIONAL AIR STRIPPER - SITE PLAN

FIGURE 4

the well pump would be subjected to additional static and dynamic head resulting in a reduction in capacity. The following paragraphs address each of these items.

### **8.3.1 Chemical Treatment System**

Based upon the total hardness levels cited in Table 1 (greater than 400 mg/L), and to a lesser degree, the manganese concentrations in the raw water of Unit Well No. 15, it is recommended that polyphosphate be fed directly ahead of the aeration unit. The purpose of the polyphosphate would be to sequester the hardness (and manganese), thereby minimizing the amount and extent of deposition on the Tripak media and aerator internals.

Presented in Table 4 are the conceptual design parameters for the polyphosphate system. It is anticipated that the polyphosphate feed will enable the aeration units to continue to operate at peak efficiency while minimizing the need for cleaning of the aerator internals and Tripak media.

**Table 4. Polyphosphate System Design Parameters**

<b>Parameter</b>	<b>Design Value</b>
Flow	2,200 gpm
Dosage	1.0 mg/L
Daily Consumption	2.3 gallons
Monthly Consumption	69 gallons

The polyphosphate storage and feed system would be located within the existing pump house as depicted in Figure 5.

The system would include chemical storage in two 55 gallon drums, providing for 30 days of storage capacity. Using a drum pump, the polyphosphate would be transferred to either a HDPE or FRP day tank set upon a scale. Redundant chemical metering pumps, with one in standby mode, would feed the polyphosphate to the aeration unit influent pipeline.

### **8.3.2 Well Pump Capacity**

The static and dynamic head associated with installation of the conventional air strippers will reduce the capacity of the pumping unit by approximately 550 gpm. Therefore, the well capacity will be reduced from 2,200 gpm to approximately 1,650 gpm (25 percent reduction). The well pump efficiency will also be reduced from 84 percent to 80 percent.

The reduced capacity of the well pump (1,650 gpm) will be less than the capacity of the booster pump (2,000 gpm). To maintain the capacity of Well No. 15, pump modifications (Installation of additional stages and replacement of the motor) or replacement of the pumping unit would be required.

A pump characteristic curve, which depicts the operational impacts associated with the installation of a conventional air stripper, is included in Appendix B.

169092 - 2000 - GENUP - C - T0001CV1X

AFIBGORD  
FAFIGBORD

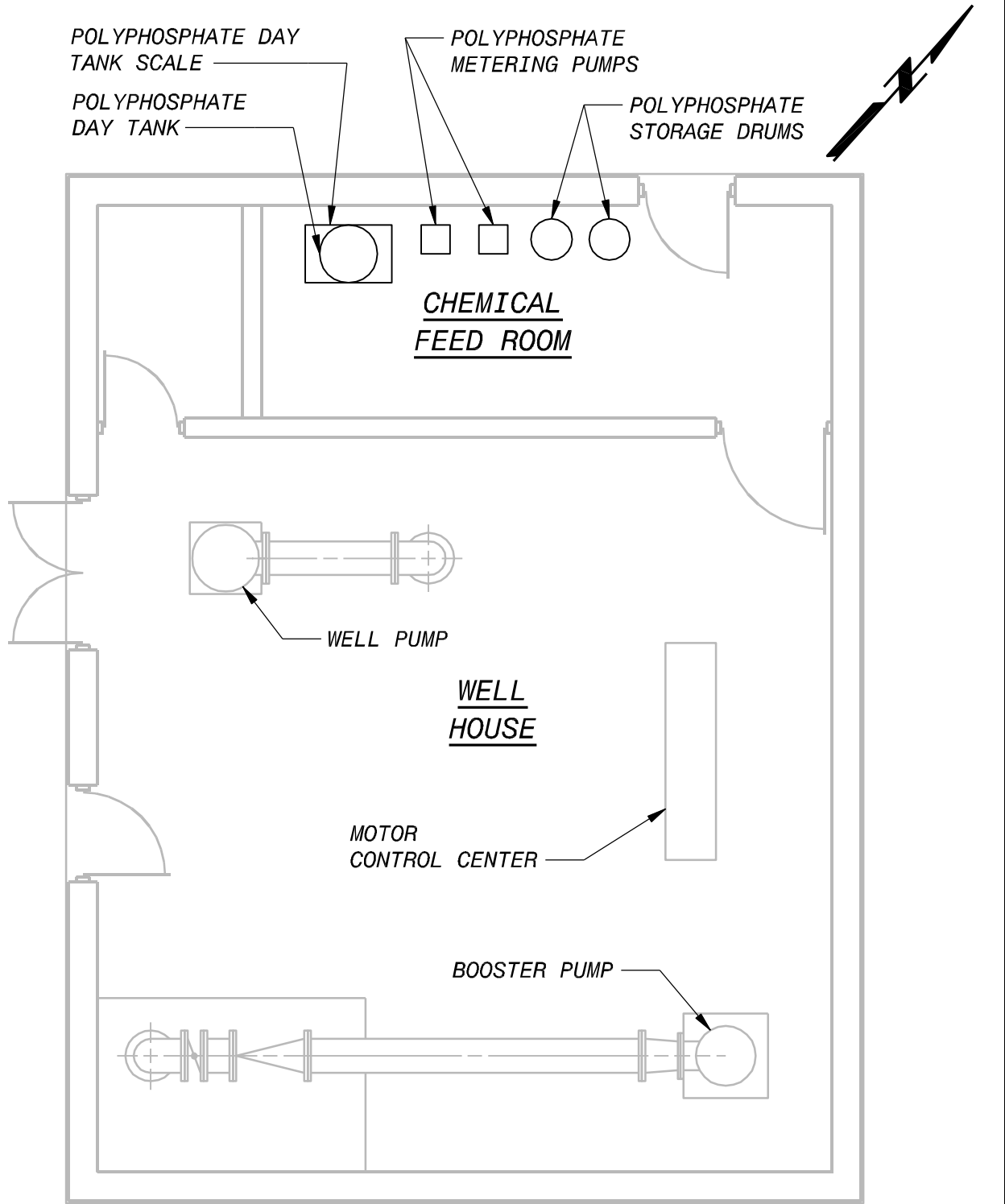

PLAN  
3/16" = 1' - 0"

MADISON, WISCONSIN  
EAST SIDE WATER SUPPLY PLANNING  
& PROJECT DEVELOPMENT



UNIT WELL NO. 15  
POLYPHOSPHATE STORAGE  
& FEED SYSTEM

FIGURE 5

#### 8.4 Off-Gas Treatment

As summarized in Table 2, the Wisconsin DNR has established hourly and annual threshold values for sources of specific hazardous air contaminants. In the case of Unit Well No. 15, the aeration units would be venting the PCE and TCE that was removed from the water column to the atmosphere.

In order to determine if vapor phase treatment of the aeration unit off-gases would be necessary, the daily and annual volume of PCE and TCE released to the atmosphere was calculated, expressed in pounds per hour and pounds per year, respectively. The basis for the calculated PCE and TCE emission values was 100 percent removal of raw water concentrations of 4 µg/L of PCE and 0.4 µg/L of TCE at a flow rate of 2,200 gpm.

The calculated values, compared to the DNR emission threshold limits, are presented in Table 5.

**Table 5. Calculated Aerator Emission Volumes**

Contaminant	DNR Emission Threshold	Calculated Volume Emitted
PCE	9.11 pounds/hour	0.0030 pounds/hour
	301 pounds/year	26.75 pounds/year
TCE	14.4 pounds/hour	0.00030 pounds/hour
	888 pounds/year	2.67 pounds/year

As indicated in Table 5, the VOC emissions from the forced draft aerator would be substantially below both the hourly and annual emission threshold limits for both PCE and TCE. Therefore, vapor phase treatment of off-gas emissions will not be required by the DNR.

Although the DNR will not require the treatment of the VOC airstream emitted from the forced draft aerator, vapor phase GAC adsorption could be used to treat the aerator emissions. VOCs are removed from the airstream using a GAC adsorption unit which would operate at a pressure of approximately 28 inches with a loading rate of 50 scfm/ft<sup>2</sup>. The GAC adsorption unit would have dimensions of 11 ft. x 11 ft. x 7 ft for a square contactor.

The estimated installed capital cost for a vapor-phase GAC adsorption unit is \$170,000 (Excludes building cost). Operating expenses would include the cost for replacement GAC, regeneration of the spent GAC, and cleaning of the adsorption vessel at the time of GAC replacement.

Another item to consider, relative to emissions from the aeration units, is the possibility that the raw water concentrations of PCE and TCE would increase over time. Given the uncertainty of the source of contamination, this is a distinct possibility. As such, the raw water concentration of PCE and TCE that would trigger the DNR requirement for vapor phase treatment was calculated. The trigger value used in this calculation was the annual threshold, as this is the more conservative of the emission threshold requirements. In the case of PCE, the raw water concentration would have to increase to approximately 41µg/L to trigger the requirement for off-gas treatment. For TCE, the raw water concentration would be approximately 91 µg/L.

## 9. LOW PROFILE AERATION

### 9.1 *Equipment and Design Parameters*

Low profile aeration units, which are based upon a cascading tray aeration concept, are becoming more prevalent in the water supply industry due to their compact design and ease of maintenance of the internal trays.

Equipment drawings and budgetary cost information was obtained for low profile aeration units from QED Environmental Systems, a company with numerous installations of low profile aeration units throughout the United States. The low profile unit conceptual design was based upon the requirements to treat a flow of 2,200 gpm and achieve a VOC removal efficiency of 99 percent. Given the current level of VOCs in the water from Unit Well No. 15, this would yield PCE and TCE concentrations below 0.04 µg/L in the aeration unit effluent.

The low profile aeration unit conceptual design for Unit Well No. 15 does not provide for redundant aeration. It is anticipated that media cleaning and routine maintenance activities would not occur during peak demand periods.

The information obtained from QED Environmental Systems is presented in Appendix A.

Two low profile units would be required to treat 2,200 gpm. Each aeration unit features a dedicated blower, a standby blower, and a stainless steel aerator housing with an internal 4 tray configuration. Table 6 summarizes the key design elements of the low profile aeration units that yield a removal efficiency level of 99 percent.

**Table 6. Low Profile Aeration Unit Design Parameters**

<b>Parameter</b>	
No. of Aeration Units	2
VOC Removal Efficiency	99 percent
Capacity of Each Unit	1,100 gpm
Hydraulic Loading Rate	3.4 gpm/sf
Air-to-Water Ratio	3.9 cfm/gpm
Dimensions of Aeration Unit	8.5 ft (l) x 12 ft (w) x 8.5 ft. (h)
Number of Trays per Unit	4
Forced Draft Blower Rating	5,200 scfm
Weight (filled with water)	22,000 pounds per unit
Expected Tray Cleaning Frequency	every 3 to 6 months

Because of the elevated hardness concentration in the water from Unit Well No. 15, provisions should be made for periodic cleaning of the trays and aerator internals. This typically consists of removal of the front door of the unit and pressure washing of the trays. The trays can either be pressure washed in place or removed and washed in a location with ready access to a drain. Alternatively, a dilute citric acid solution can be circulated in each unit. This requires the proper handling and disposal of the spent acid solution.

Based upon information provided by the equipment vendor, it is expected that the low profile aeration units will require cleaning at a frequency of two to four times each year. The cleaning



cycle can be completed in less than one day. Given the importance of Unit Well No. 15 to the City's Zone 6 - East Service Area, it must be determined if the well can be removed from service when cleaning is required. If it is determined that the cleaning frequency would be operationally disruptive, a redundant aeration unit could be installed to maintain constant flow from the facility.

## **9.2 Building and Site Layout**

Although the air strippers could be located outdoors above the reservoir, it is our understanding that MWU's preference is to locate the equipment in a building. A conceptual building plan and section is depicted in Figure 6. A conceptual site plan is depicted in Figure 7. As indicated on the site plan, additional property would need to be acquired to accommodate the building.

## **9.3 Operational Impacts**

The installation of a low profile aerator at Unit Well No. 15 site would require an additional chemical treatment system to reduce the frequency of media cleaning activities. Also, the well pump will be subjected to additional static and dynamic head losses resulting in a reduction in capacity. The following paragraphs address each of these items.

### **9.3.1 Chemical Treatment System**

The installation of low profile aeration units at the Unit Well No. 15 site would require an additional chemical treatment system. The discussion of chemical treatment for the low profile aeration units is the same as was presented for the conventional air stripper units. The polyphosphate would be fed to the aerator influent pipeline.

### **9.3.2 Well Pump Capacity**

The static and dynamic head associated with installation of the low profile aeration units would reduce the capacity of the pumping unit by approximately 200 gpm. Therefore, the well capacity will be reduced from 2,200 gpm to approximately 2,000 gpm (9 percent reduction). The well pump efficiency will also be reduced from 84 percent to 83 percent.

The reduced capacity of the well pump (2,000 gpm) will be approximately equal to the capacity of the booster pump (2,000 gpm). To maintain the capacity of Well No. 15, it is likely that pump modifications (installation of additional stages and replacement of the motor) or replacement of the pumping unit would be required.

A pump characteristic curve, which depicts the operational impacts associated with the installation of the low profile aerators, is included in Appendix B.

## **9.4 Off-Gas Treatment**

The discussion of off-gas treatment for the low profile aeration units is the same as was presented for the forced draft aeration units.

## **10. GRANULAR ACTIVATED CARBON ADSORPTION**

GAC Adsorption is a very effective mechanism for removal of the VOCs that are present in the raw water from Unit Well No. 15. Equipment drawings and budgetary cost information for GAC adsorbers was obtained from Siemens and WesTech, based upon the requirements to treat a flow of 2,200 gpm and achieve a VOC removal efficiency of 99 percent. Given the current level

169092-2000-GENUP-C-T0001DL5N

BFIGBORD  
BFIGBORD



**PLAN**  
3/16" = 1'-0"

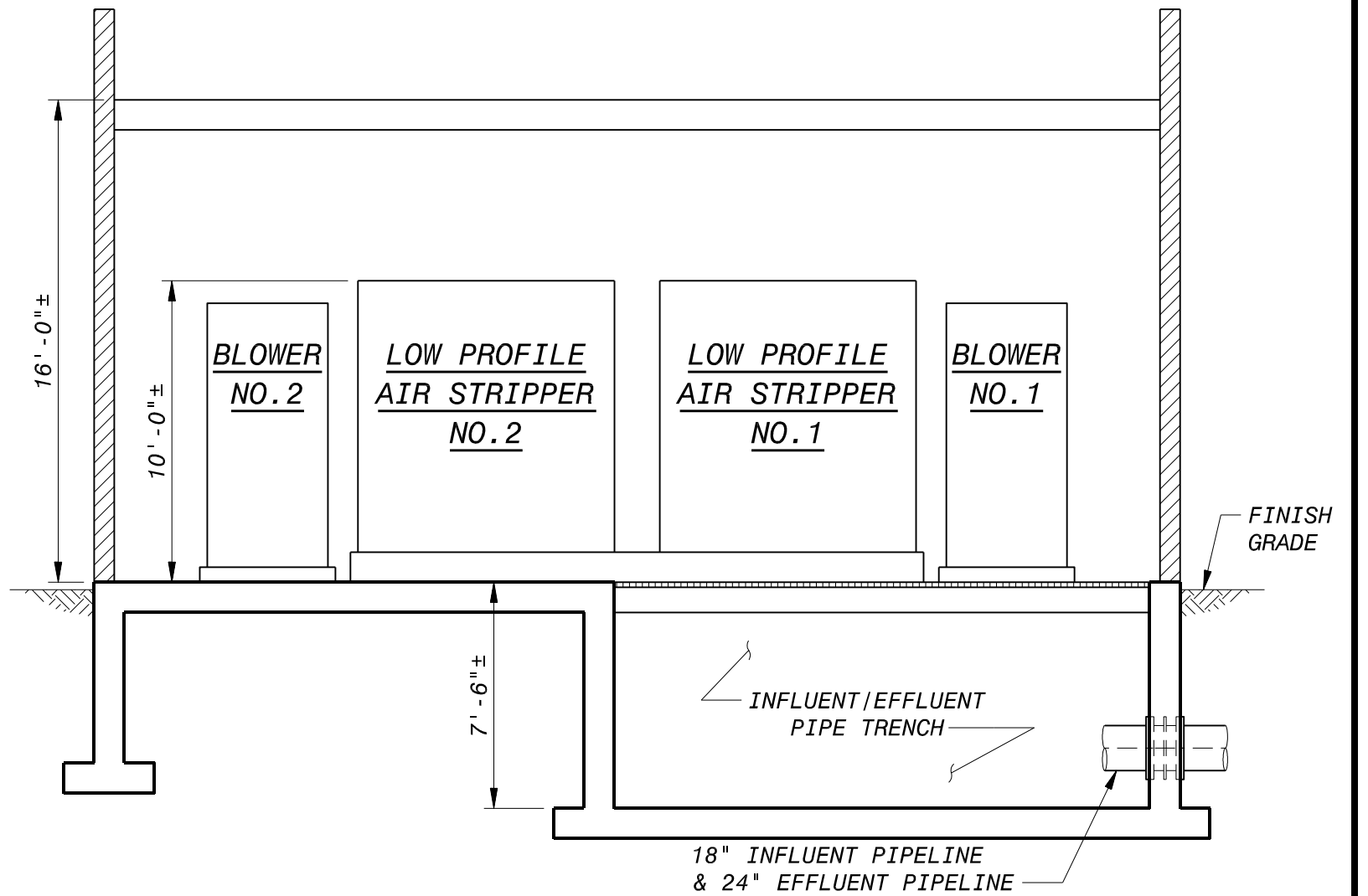
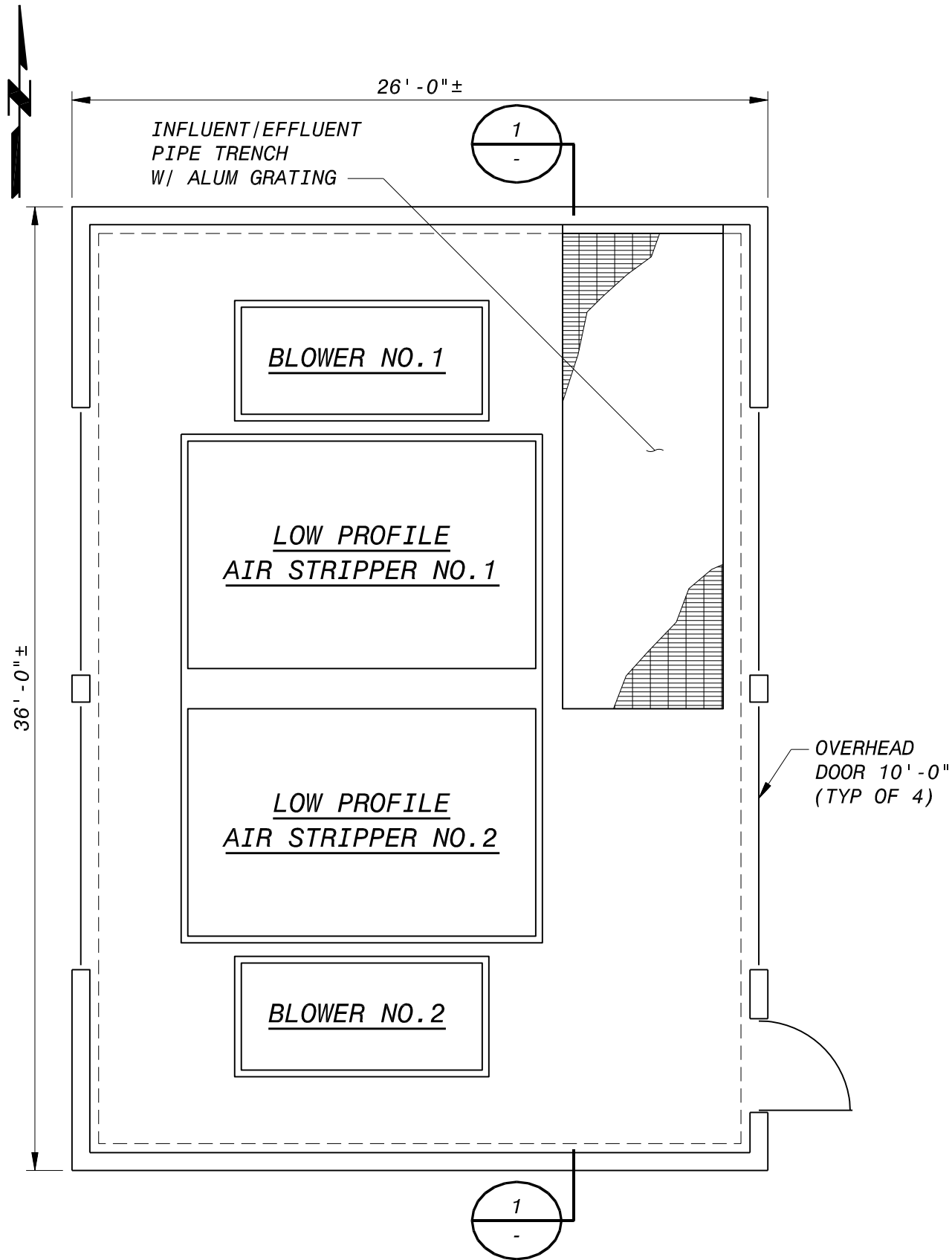

**SECTION 1**  
3/16" = 1'-0"

MADISON, WISCONSIN  
 EAST SIDE WATER SUPPLY PLANNING  
 & PROJECT DEVELOPMENT  
 UNIT WELL NO. 15  
 LOW PROFILE AIR STRIPPER BUILDING  
 PLAN & SECTION

FIGURE 6

169092-2000-WTCN-C-T0001DLT1

BFIGBORD  
BFIGBORD

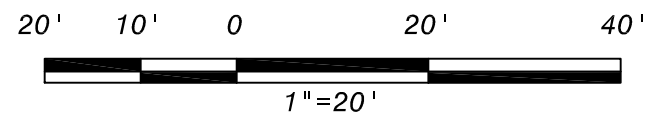

MADISON, WISCONSIN  
 EAST SIDE WATER SUPPLY PLANNING  
 & PROJECT DEVELOPMENT

UNIT WELL NO. 15  
 LOW PROFILE AIR STRIPPER - SITE PLAN

FIGURE 7

of VOCs in the water from Unit Well No. 15, this would yield PCE and TCE concentrations below 0.40 µg/L in the GAC adsorber effluent.

Table 7 summarizes the key design elements of the GAC adsorbers as provided by the contacted vendors.

**Table 7. GAC Adsorption Unit Design Parameters**

<b>Parameter</b>	<b>Siemens</b>	<b>WesTech</b>
No. of Adsorption Vessels	2	3
Capacity of Each vessel	1,100 gpm	733 gpm
Empty Bed Contact Time	7.5 minutes/vessel	13.6 minutes/vessel
Design Loading Rate	3.0 gpm/sf	5.9 gpm/sf
Dimensions of each Vessel	12 ft. diameter; 19 ft. height	12 ft. diameter; 16 ft. height
Vessel Carbon Capacity	30,000 pounds GAC	40,000 pounds GAC
Vessel Weight (filled with GAC and water)	120,000 pounds	undetermined
Expected Media Replacement Frequency	1.6 years	undetermined

Although Siemens and WesTech proposed the use of two and three vessels respectively, an additional vessel may be necessary in order to allow for occasional backwashing or “fluffing” of the GAC media while maintaining full capacity from the Unit Well No. 15 facility. An additional GAC adsorption unit would not be required if backwashing operations could occur during off peak demand periods without adversely affecting operations.

The GAC contactors must be housed within a building in order to protect them from the elements (freezing temperatures). As such, a building with the dimensions of 54 feet in length by 24 feet in width is necessary to house the GAC vessels. As depicted in Figure 8, the site area would limit the construction of a building to accommodate the GAC adsorption vessels without property acquisition. The site limitations, coupled with a conceptual capital cost that is approximately 3.5 to 6 times higher than aeration technology, eliminate GAC adsorption from consideration as a viable treatment technology at Unit Well No. 15.

## 11. CONCEPTUAL OPINION OF PROBABLE PROJECT AND LIFE CYCLE COSTS

The following paragraphs present the conceptual opinion of probable costs for forced draft aeration and low profile aeration at Unit Well No. 15. The costs include the budgetary equipment costs provided by the vendors, costs associated with upgrades to the site and existing facilities to accommodate the treatment systems, operation and maintenance costs, and 20-year life cycle costs.

### 11.1 Conventional Air Strippers

Table 8 depicts the estimated capital costs associated with a forced draft aeration system with a capacity of 2,200 gpm that will achieve a removal efficiency of 99 percent. Should it be necessary to incorporate vapor phase treatment of off-gases, it is expected that this will increase the installed capital cost by approximately \$170,000 for each system.

169092-2000-GENUP-C-T0001CW55

BFIGBORD  
BFIGBORD

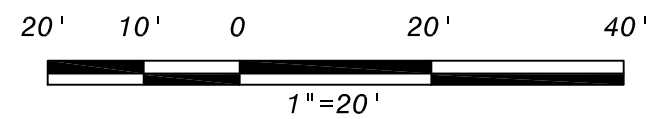

MADISON, WISCONSIN  
 EAST SIDE WATER SUPPLY PLANNING  
 & PROJECT DEVELOPMENT

UNIT WELL NO. 15  
 GRANULAR ACTIVATED  
 CARBON (GAC) CONTACTORS

FIGURE 8

**Table 8. Conceptual Opinion of Probable Project Costs  
 Conventional Air Strippers**

<b>Description</b>	<b>Conceptual Opinion of Probable Project Costs</b>
Building, piping and valves	\$610,000
Equipment	\$250,000
Polyphosphate storage and feed system (Recommended, but optional)	\$25,000
Vertical Diffusion Vane Well Pump	\$125,000
Administrative, Engineering, and Legal	\$150,000
Contingency (Approx. 25%)	\$290,000
<b>Estimated Total Project Cost</b>	<b>\$1,450,000</b>

Table 9 depicts the estimated annual operation and maintenance costs for the conventional air stripper systems.

**Table 9. Operation and Maintenance Cost  
 Conventional Air Strippers**

<b>Description</b>	<b>Conceptual Opinion of Probable Annual Costs</b>
Maintenance	\$10,000
Electrical	\$11,500
Chemicals	\$1,500
<b>Estimated Total</b>	<b>\$23,000</b>

**11.2 Low Profile Aeration**

Table 10 depicts the estimated capital costs associated with a low profile aeration system with a capacity of 2,200 gpm that will achieve a removal efficiency of 99 percent. Should it be necessary to incorporate vapor phase treatment of off-gases, it is expected that this will increase the installed capital cost by approximately \$170,000 (Excludes building cost).

**Table 10. Conceptual Opinion of Probable Project Costs  
 Low Profile Aeration System**

<b>Description</b>	<b>Conceptual Opinion of Probable Project Costs QED Environmental Systems</b>
Building, piping and valves	\$615,000
Equipment	\$675,000
Polyphosphate storage & feed system (Recommended, buy optional)	\$25,000
Vertical Diffusion Vane Well Pump	\$125,000
Administrative, Engineering, and Legal	\$215,000
Contingency (Approx. 25%)	\$415,000
<b>Estimated Total Project Cost</b>	<b>\$2,070,000</b>

Table 11 depicts the estimated annual operation and maintenance costs for the low profile aeration system.

**Table 11. Operation and Maintenance Cost  
 Low Profile Aeration System**

<b>Description</b>	<b>Conceptual Opinion of Probable Annual Costs QED Environmental Systems</b>
Maintenance	\$10,000
Electrical	\$9,000
Chemicals	\$1,500
<b>Estimated Total</b>	<b>\$20,500</b>

### 11.3 20-Year Life Cycle Costs

Presented in Table 12 are the 20-Year Life Cycle Cost Estimates for the conventional air stripper system and the low profile aeration system. An annual interest rate of four percent was used to calculate the 20-Year estimates.

**Table 12. 20-Year Life Cycle Cost Estimates  
 Forced Draft and Low Profile Aeration Systems**

<b>Aeration System</b>	<b>20-Year Life Cycle Cost Estimate</b>
Conventional Air Stripper	\$1,765,000
Low Profile Aeration System	\$2,350,000

## 12. EVALUATION SUMMARY

Three alternative treatment technologies were evaluated for removal of volatile organic compounds (VOC) at Unit Well No. 15. The treatment technologies included conventional air strippers, low-profile air strippers and granular activated carbon (GAC) adsorption units.

Considering the site space limitations, GAC adsorption units are not considered a viable alternative for treatment at Unit Well No. 15.

The use of conventional and low-profile air stripper units are both considered viable treatment options.

The height of the building required to accommodate conventional forced draft and low profile aerators is approximately 34 ft. and 16 ft., respectively. From an aesthetics standpoint, the use of low profile units will be less obtrusive.

The water hardness, iron and manganese concentrations will cause deposition on the conventional air stripper media and the low profile air stripper trays. Frequent cleaning of the media or trays will be required. Feeding a sequestering agent upstream of the equipment is recommended to reduce the cleaning frequency. It will be difficult to clean the Tripak media in a conventional air stripper. If the media is not effectively cleaned, the frequency of cleaning activities will increase. The design of the low profile air strippers facilitate a simplified and effective cleaning process.

The conceptual opinion of probable project cost and 20-year life cycle cost for a conventional air stripper is \$1,450,000 and \$1,765,000, respectively. The conceptual opinion of probable project cost and 20-year life cycle cost for low profile air strippers is \$2,070,000 and \$2,350,000, respectively.

The conceptual opinion of probable project cost would be approximately \$620,000 lower for conventional air strippers. In addition, the estimated 20-year life cycle cost would be approximately \$585,000 lower for conventional air strippers.



**APPENDIX A**  
**Equipment Information**

DRAFT

**WESTECH**  
an employee-owned company

Proposal For:



Project:

**Madison, WI**

Equipment:

**One (1) Forced Draft Aerator  
WesTech Model No. AWF51**

Represented By:

**Ray Lindsey Company  
17221 Bel Ray Place  
Belton, MO 64012  
Contact: Dan Batliner  
Phone: (816) 388-7440  
Fax: (816) 388-7434  
[dbatliner@raylindsey.com](mailto:dbatliner@raylindsey.com)**

**Drydon Equipment, Inc.  
W 5375 Michael Dr.  
Hilbert, WI 54129  
Contact: Tom Dennis  
Phone: (920)439-1188  
Fax: (920)439-1079  
[tdennis@drydon.com](mailto:tdennis@drydon.com)**

Furnished By:

**WesTech Engineering, Inc.  
Salt Lake City, UT 84115  
Phone: (801) 265-1000  
E-mail: [jblattman@westech-inc.com](mailto:jblattman@westech-inc.com)**

**WesTech Proposal: 1030186  
Date: November 16, 2010**

**ITEM "A"- One (1) Forced Draft Aerator  
WesTech Model No. AWF51**

The following information was used in the design of the aerator provided in this proposal. The following values were used to calculate a 99% removal rate, some of them are assumed, so all information should be verified by the engineer.

Use	Tetrachloroethylene/Trichloroethylene Removal
Design Peak Capacity	2,000 gpm
Water Loading Rate	24.7 gpm/sq. ft.
Water Temperature	55 <sup>o</sup> F
Air/Water Ratio	3.0 cfm/gpm
Air flow	6,075 SCFM
Inside Dimensions	9'-0" x 9'-0" x 15'-0' high
Outside Dimensions	9'-6" x 13'-3" (w/ blower) x 19'-6" high
Media	Loose fill

**UNIT FURNISHED COMPLETE WITH THE FOLLOWING COMPONENTS:**

One (1) aluminum aerator housing shell with approximate dimensions of 9'-0" x 9'-0" x 15' high (inside). Housing includes a removable bolted side panel, screened air intakes, inspection port below the internals, 12" flanged top inlet connection, and 16" diameter plain end effluent pipe. Inspection manhole and one (1) air exhaust connection with moisture separators and inspection manhole in cover.

One (1) aluminum distribution tray with velocity breaker box, and aluminum air stacks.

Ten (10) feet of ½" –1" Tripak.

One (1) forced draft blower rated at 6,075 scfm at 2" static pressure with aluminum hooded screened intake. The blower will be of the non-overloading centrifugal type. Transition hood between the blower and the aerator shell is provided.

One (1) lot type stainless steel anchor bolts with nuts for mounting the unit.

**QUALITY ASSURANCE PROGRAM**

WesTech prides itself on its quality products and customer service. Recognizing the importance of continuous improvement, WesTech has developed a quality management system in order to meet our customer's needs for exceptional quality and service. This system is based on, and complies with, the International Organization for Standardization's ISO-9001 standard, and its technical U.S. equivalent ANSI/ASQC Q9001.

Aerator is shipped fully assembled except for blower assemblies, transition hood, and exhaust hood which will require field mounting.

**TOTAL SERVICE**

WesTech will provide the service of a qualified representative for one (1) trip and two (2) days to inspect the mechanism installation, assist in start-up, and instruct plant personnel in the proper operation and maintenance of the mechanism.

**FREIGHT**

Freight is included FOB to jobsite

**CLARIFICATIONS**

The clarifications required for the system being supplied are as follows:

1. Aerator influent flanged connection is not designed to support the weight of the influent piping. Alternate means of influent pipe support should be provided.
2. The system is designed for 99% removal of tetrachloroethylene and trichloroethylene removal at the given conditions.

**NOTE: ANY ITEM NOT LISTED ABOVE TO BE FURNISHED BY OTHERS.**

ITEMS NOT BY WESTECH: Electrical wiring, conduit or electrical equipment, piping, valves, or fittings, lubricating oil or grease, shop or field painting, field welding, erection, detail shop fabrication drawings, sludge blow down controls, performance testing, bonds, unloading, storage, concrete work, field service, (except as specifically noted).

This proposal section has been reviewed for accuracy and is approved for issue:

By: *Trent Mortensen*

Date: November 16, 2010

## BUDGET PRICING

Unless otherwise indicated, prices listed below are for equipment only. All optional items will be offered with the purchase of the scoped equipment only and will not be sold separately. Prices are for a period not to exceed 30 days from date of proposal.

ITEM	EQUIPMENT	BUDGET PRICE (U.S. \$)
"A"	One (1) Forced Draft Aerator WesTech Model No. AWF51	\$ <u>130,000.00</u>

Terms: Terms for equipment are 15 percent payment of the purchase price with submittal drawings, 35 percent upon receipt of major material in shop, and 50 percent net 30 days from shipment.

O & M Manuals: Operation and maintenance manuals are included in the above equipment price. Manuals will be provided before the equipment ships.

Sales Tax: No sales tax, use taxes, or duties have been included in our pricing.

Freight: Prices quoted are F.O.B. shipping point with freight allowed to a readily accessible location nearest to jobsite. All claims for damage or loss in shipment shall be initiated by purchaser.

Submittals: Shop drawing submittals will be made approximately 6 to 8 weeks after purchase order is received in our office.

Shipment: Estimated shipment time is 16 to 18 weeks after approved shop drawings are received in our office.

Field Service: Prices do not include field service unless noted in equipment description and as broken out as a separate item. Additional field service is available at \$ 960.00 per day plus expenses.

Shipment/Extended Storage: If equipment installation and start-up are delayed more than 30 days, extended storage instructions must be requested from WesTech and the provisions of these instructions must be followed to keep WARRANTY in force.

Terms and Conditions: This proposal, including all terms and conditions contained herein, shall become part of any resulting contract or purchase order. Changes to any terms and conditions, including but not limited to submittal and shipment days, payment terms, and escalation clause shall be negotiated at order placement. Otherwise, the proposal terms and conditions contained herein shall apply.

Paint: If your equipment has paint included in the price, please take note of the following. Primer paints are designed to provide only a minimal protection from the time of application (usually for a period not to exceed 30 days). Therefore, it is imperative that the finish coat be applied within 30 days of shipment on all shop primed surfaces. Without the protection of the final coatings, primer degradation may occur after this period, which in turn may require renewed surface preparation and coating. If it is impractical or impossible to coat primed surfaces within the suggested time frame, WesTech strongly recommends the supply of bare metal, with surface preparation and coating performed in the field. All field surface preparation, field paint, touch-up, and repair to shop painted surfaces are not by WesTech.

## **WARRANTY**

**WesTech equipment is backed by WesTech's reputation as a quality manufacturer, and by many years of experience in the design of reliable equipment.**

**Equipment manufactured or sold by WesTech Engineering, Inc., once paid for in full, is backed by the following warranty:**

**For the benefit of the original user, WesTech warrants all new equipment manufactured by WesTech Engineering, Inc. to be free from defects in material and workmanship, and will replace or repair, F.O.B. its factories or other location designated by it, any part or parts returned to it which WesTech's examination shall show to have failed under normal use and service by the original user within one (1) year following initial start-up, or eighteen (18) months from shipment to the purchaser, whichever occurs first. Such repair or replacement shall be free of charge for all items except for those items such as resin, filter media and the like that are consumable and normally replaced during maintenance, with respect to which, repair or replacement shall be subject to a pro-rata charge based upon WesTech's estimate of the percentage of normal service life realized from the part. WesTech's obligation under this warranty is conditioned upon its receiving prompt notice of claimed defects, which shall in no event be later than thirty (30) days following expiration of the warranty period, and is limited to repair or replacement as aforesaid.**

**THIS WARRANTY IS EXPRESSLY MADE BY WESTECH AND ACCEPTED BY PURCHASER IN LIEU OF ALL OTHER WARRANTIES, INCLUDING WARRANTIES OF MERCHANTABILITY AND FITNESS FOR PARTICULAR PURPOSE, WHETHER WRITTEN, ORAL, EXPRESS, IMPLIED, OR STATUTORY. WESTECH NEITHER ASSUMES NOR AUTHORIZES ANY OTHER PERSON TO ASSUME FOR IT ANY OTHER LIABILITY WITH RESPECT TO ITS EQUIPMENT. WESTECH SHALL NOT BE LIABLE FOR NORMAL WEAR AND TEAR, CORROSION, OR ANY CONTINGENT, INCIDENTAL, OR CONSEQUENTIAL DAMAGE OR EXPENSE DUE TO PARTIAL OR COMPLETE INOPERABILITY OF ITS EQUIPMENT FOR ANY REASON WHATSOEVER.**

**This warranty shall not apply to equipment or parts thereof which have been altered or repaired outside of a WesTech factory, or damaged by improper installation, application, or maintenance, or subjected to misuse, abuse, neglect, accident, or incomplete adherence to all manufacturer's requirements, including, but not limited to, Operations & Maintenance Manual guidelines & procedures.**

**This warranty applies only to equipment made or sold by WesTech Engineering, Inc.**

**WesTech Engineering, Inc. makes no warranty with respect to parts, accessories, or components purchased by the customer from others. The warranties which apply to such items are those offered by their respective manufacturers.**

**QED e-Quote** version c1.00

Generated: 10/27/2010

e-Quote prepared for :

**Q1010-33036 - 10/27/2010****Kevin Dixon** ([dixonkl@bv.com](mailto:dixonkl@bv.com))**Sales Person: Ken Still**  
([kstill@qedenv.com](mailto:kstill@qedenv.com))Black & Veatch  
1120 Sanctuary Parkway  
Suite 200QED Envir. Systems - Regional Sales Mgr.  
Phone: 770-466-5566



Alpharetta, GA 30009

**Prepared by: Chris Jacobs**  
([cjacobs@qedenv.com](mailto:cjacobs@qedenv.com))

Phone: 770-752-5259

Fax:

**Site Reference: Madison, WI**Click -  for more information (available for some parts).

Details					
Item	Part No.	Quantity	Part Description	Unit Price (\$)	Ext. Price (\$)
1	<b>EZ-96.4SS</b>	2.0	Air Stripper Assy, 4 Tray, 1000 GPM <i>Find more information at -  </i>	135,000.00	270,000.00
2	<b>807190</b>	2.0	Blower, pressure / mfg. New York Blower. Motor: 75 hp, 460 volt, 3-phase, TEFC. Inlet: 12" OD - discharge: 12" flange 150 lb. class. Standard on a EZ-96.X stainless steel. <i>Blower rated at 5200 cfm.</i>	8,000.00	16,000.00
3	<b>BLKIT12</b>	2.0	Blower piping kit, 12" PVC SCH40 pipe & flange (150# class). Designed for EZ-48.x and EZ-96.x stainless steel series air strippers. Blower to sump piping kit for QED skid mounted systems.	1,985.00	3,970.00
4	<b>GDKIT10</b>	2.0	Gravity drain piping kit, for EZ-48.x or 96.x stainless steel series. 8-10" PVC pipe designed for use on QED skidded system.	850.00	1,700.00
5	<b>EZ-LOWP</b>	2.0	Kit, blower low air pressure sump switch (explosion-proof). Includes: (1) EZPLOW pressure switch, tubing & fittings.	195.00	390.00
6	<b>EZ-DIS</b>	2.0	Sump discharge pump float switch kit. Includes: (1) 800065 warrick float switch & (1) cord strain relief. Note: Requires intrinsically-safe relay for explosive environments. QED p/n CPIS.	135.00	270.00
7	<b>EZ-HIGHLV</b>	2.0	Sump high level float switch kit (non-exp). Includes: (1) 800065 warrick float switch & (1) cord strain relief. Note: Requires intrinsically-safe relay for explosive environments. QED p/n CPIS.	135.00	270.00
8	<b>SCPAS-96.X</b>	2.0	CONTROL PANEL STANDARD DESIGN: Control panel is weatherproof (UL, NEMA 4 rating), with air stripper blower motor starter, HOA switch, green running light, red stripper sump high level alarm light, red low air pressure alarm light, circuit breakers and relays for controlling stripper and main disconnect. Unless otherwise indicated, the QED panel will control only the equip listed in this quote. NOTE: If site is Class I Division I or II, the control panel must be remote mount.	20,000.00	40,000.00



9	EZ-L6	2.0	LABOR, Assembly of QED Skid mounted Air Stripper systems. Standard on EZ-72.X, EZ-96.X Stainless Steel Air Strippers.	1,950.00	3,900.00
10	SKID-96	2.0	Skid, platform for QED EZ-96.x stainless steel series air strippers. Material: C3 x 5.0# welded steel construction with forklift access holes. Finish: PPG pit guard two part epoxy paint over an epoxy primer. Designed for QED's blower, and (2) pumps and control panel mounts.	3,185.00	6,370.00
<b>Estimate Total:</b>				<b>\$ 342,870.00</b>	

<b>Optional Item(s)</b>					
11	EZ-T9	2.0	Spare tray (1) for an EZ-96.x stainless steel air stripper. Pricing is per tray. Please order 32 or 48 for a complete set. Qty. for a 4 tray unit (12) R.H. (12) L.H. (8) bottom (LH & RH). Qty. for a 6 tray unit (20) R.H. (20) L.H. (8) bottom (LH & RH). Note:a minimum (1) L.H and (1) R.H must be ordered.	900.00	1,800.00
12	807203	1.0	EZ-Tray Air Stripper Disassembly Tool Kit - The kit includes a tray removal tool that allows easy slide out of trays and a knob removal tool that chucks into a portable drill and quickly spins off the knobs securing the front door during disassembly or cleaning	120.00	120.00

**Terms and Conditions:** A purchase order with a 30% deposit required upon placing order. Balance plus shipping & handling is due within 30 days of shipping. Prices do not include freight: FOB Factory. QED's standard storage rates will apply to orders held for more than 2 weeks beyond assigned shipping date. Orders not shipped when completed at the customer's request are invoiced at time of completion. Prices do not include state or local taxes, where applicable. Past due invoices are subject to a 1% service charge per month. Normal shipment is 8-10 weeks from QED's receipt of customer signed Approval Package 1 and acceptance of order. After seller accepts, NO order may be canceled without Seller's written consent. Cancellation, if approved, is subject to reasonable restocking and/or handling fees. All returned products will be sent freight prepaid to Seller's facility. Two (2) O & M manuals are included with each system, additional manuals are available for a charge. All systems shipped pre-assembled and factory tested unless otherwise specified. Quote is valid for 30 days from date of quotation. All prices are in U.S. Dollars. **PRICES ARE BASED ON THE PURCHASE OF ALL ITEMS QUOTED. VERIFY PRICING ON COMPONENT ONLY PURCHASES.**

**Invoice**

**To:** \_\_\_\_\_ **Ship To:** \_\_\_\_\_

Invoice To \_\_\_\_\_ Ship To \_\_\_\_\_  
 Above \_\_\_\_\_ Above \_\_\_\_\_  
 Address [ ] \_\_\_\_\_ Address [ ] \_\_\_\_\_

**Attn:** \_\_\_\_\_

Accepted by: \_\_\_\_\_ Title: \_\_\_\_\_

Print Name: \_\_\_\_\_ Company: \_\_\_\_\_

PO Number: \_\_\_\_\_ Date: \_\_\_\_\_

**Requested Delivery Date:** \_\_\_\_\_

**To place your order, please complete the above section and email or fax back to QED at 734-995-1170.**

*(Please note that a hard copy of your PO may be required before shipment.)*

When placing orders, please make paperwork out to:

QED Environmental Systems, Inc. - PO Box 3726 - Ann Arbor, MI, 48106 - PH-800-624-2026 - FX-734-995-1170

***Our Remit To Address is: QED Environmental Systems, Inc. - W4870 - PO Box 7777 - Philadelphia, PA 19175-4870***

Ref. Quote: Q1010-33036, Rev., Amount: \$ 342,870.00

THE INFORMATION CONTAINED IN THIS DRAWING IS THE SOLE PROPERTY OF Q.E.D. ENVIRONMENTAL. ANY REPRODUCTION IN PART OR WHOLE WITHOUT THE WRITTEN PERMISSION OF Q.E.D. ENVIRONMENTAL IS PROHIBITED.

REVISIONS					
REV.	DESCRIPTION	ECO #	DRAWN BY	CHECKED BY	DATE

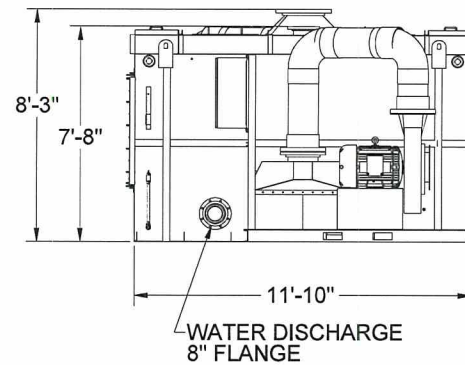
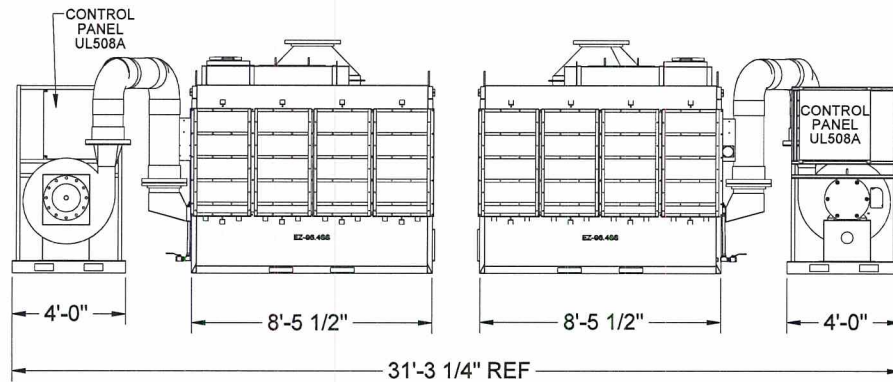
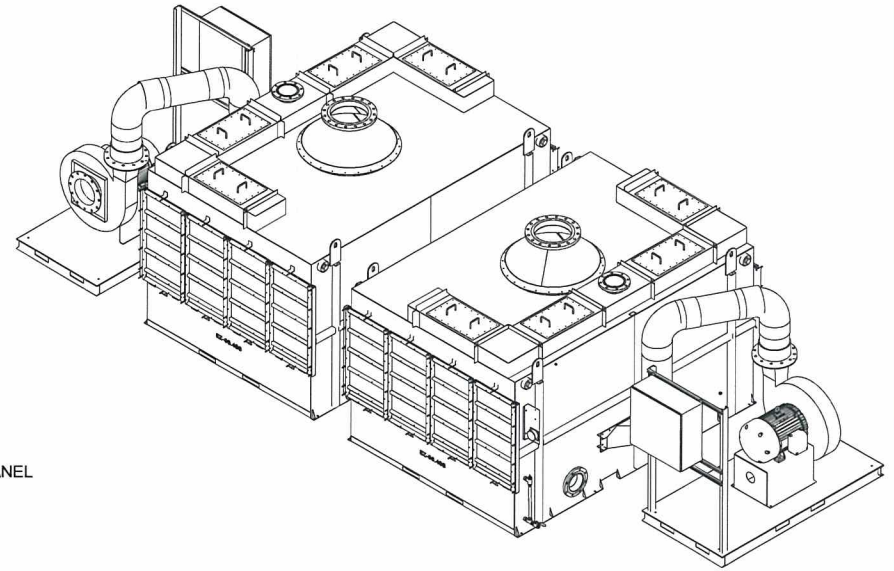
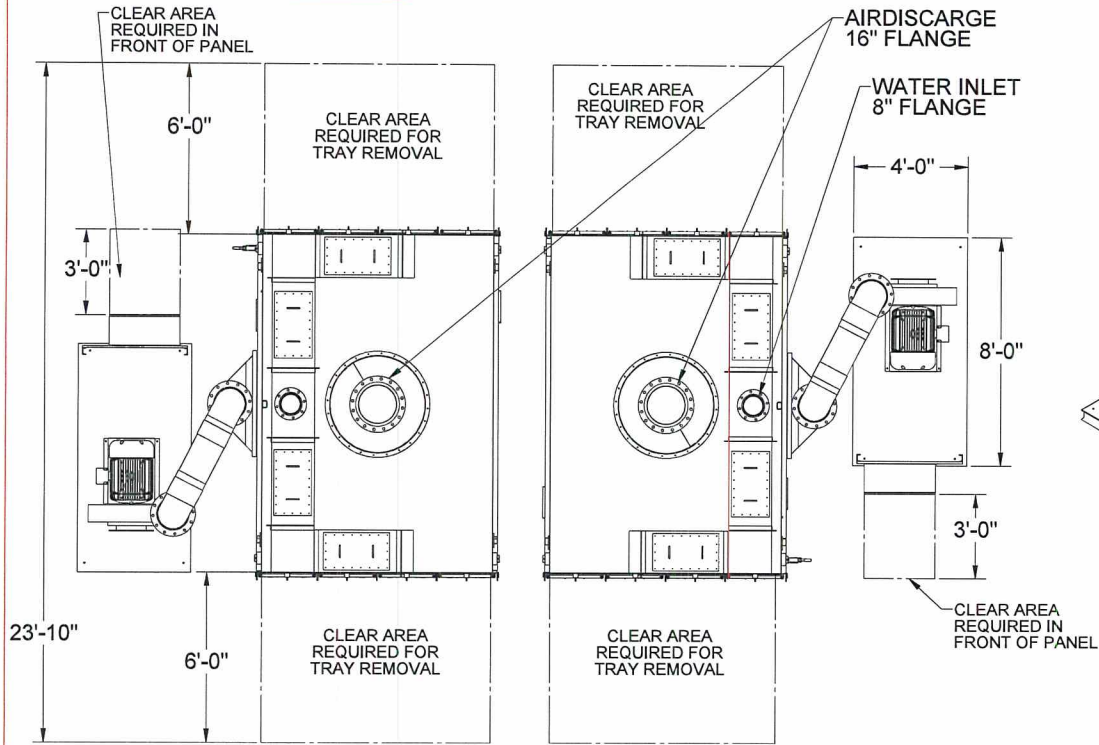

UNLESS OTHERWISE SPECIFIED, DIMENSIONS ARE IN INCHES AND INCLUDE PLATING REMOVE ALL BURRS	DRAWN BY	DATE	 6155 JACKSON ROAD, ANN ARBOR, MI. 48103
	BS	10-27-10	
	CHECKED BY	DATE	
	CJ	10-27-10	
TOLERANCES	APPROVED BY	DATE	TITLE
XX +/- .01 FRACT +/- 1/64	DC	10-27-10	
XXX +/- .005 ANGLES +/- 1/2			
OTHER TOLERANCES AS SPECIFIED			
NEXT ASSY -	MATERIAL -	DWG. NO. 10T-33036 LAYOUT	REV.
USED ON -	FINISH -	SCALE 1:36	SHEET 1 OF 1

## **APPENDIX B**

### **Well Pump Characteristic Curves**

DRAFT

# Conventional AIR STRIPPER

## PUMP DATA SHEET Turbine 60 Hz

Company: Water Well Solutions  
 Name:  
 Date: 05/07/09

UW #15 Well Pump



**Pump:**

Size: 14RJHC (2 stages)  
 Type: Lineshaft  
 Synch speed: 1800 rpm  
 Curve: E6414RCPC2  
 Specific Speeds:

**Dimensions:**

Vertical Turbine:

Speed: 1770 rpm  
 Dia: 8.9375 in  
 Impeller:  
 Ns: 3032  
 Nss: ---  
 Suction: --- in  
 Discharge: --- in  
 Bowl size: 13.63 in  
 Max lateral: 1 in  
 Thrust K factor: 13 lb/ft

**Search Criteria:**

Flow: 2200 US gpm

Head: 140 ft

**Fluid:**

Water  
 SG: 1  
 Viscosity: 1.105 cP  
 NPSHa: --- ft

Temperature: 60 °F  
 Vapor pressure: 0.2563 psi a  
 Atm pressure: 14.7 psi a

**Motor:**

Standard: NEMA  
 Enclosure: TEFC

Size: 100 hp  
 Speed: 1800  
 Frame: 405T

Sizing criteria: Max Power on Design Curve

**Pump Limits:**

Temperature: 120 °F  
 Pressure: 340 psi g  
 Sphere size: 0.98 in

Power: --- hp  
 Eye area: --- in<sup>2</sup>

--- Data Point ---  
 Flow: 2200 US gpm  
 Head: 140 ft  
 Eff: 84.4%  
 Power: 92.2 hp  
 NPSHr: 31.9 ft

--- Design Curve ---  
 Shutoff Head: 190 ft  
 Shutoff dP: 82.2 psi  
 Min Flow: --- US gpm  
 BEP: 84.7% eff  
 @ 2135 US gpm  
 NOL Pwr: 94.7 hp  
 @ 2609 US gpm

--- Max Curve ---  
 Max Pwr: 118 hp  
 @ 2820 US gpm

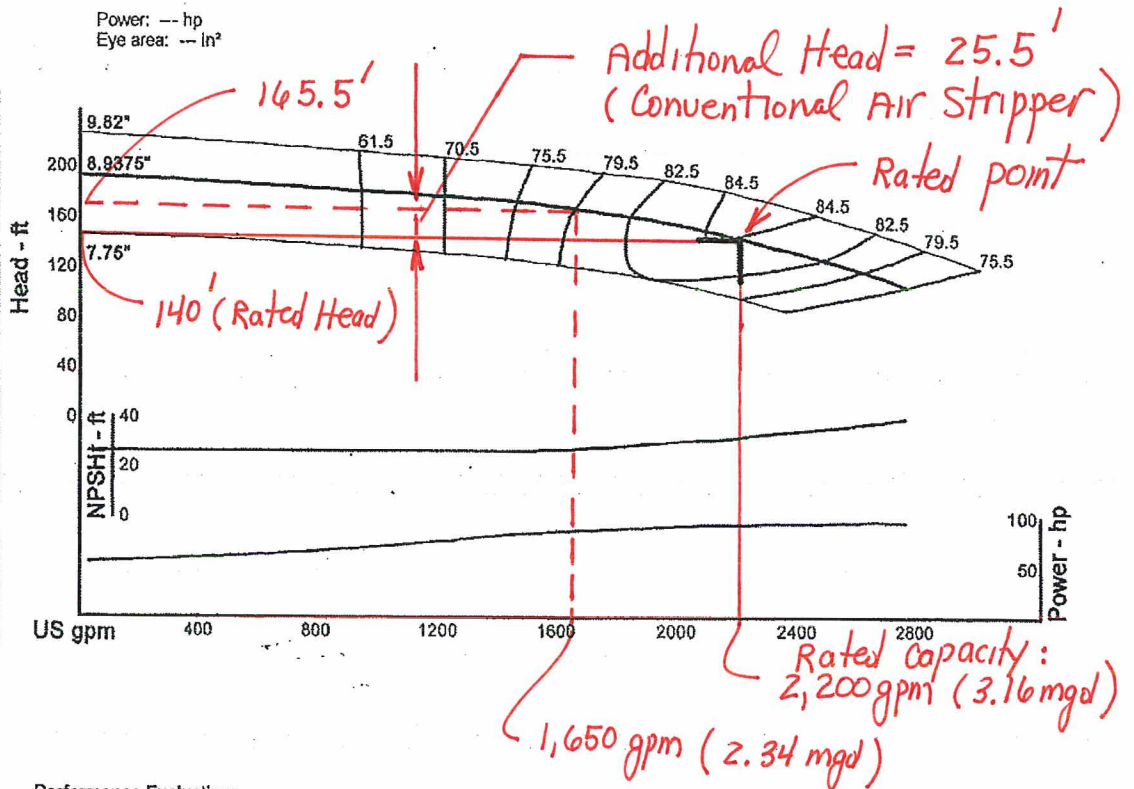

**Performance Evaluation:**

Flow US gpm	Speed rpm	Head ft	Pump %eff	Power hp	NPSHr ft
2640	1770	112	78.6	94.6	37.5
2200	1770	140	84.4	92.2	31.9
1760	1770	160	81.2	87.6	27.5
1320	1770	172	72.6	78.5	26
880	1770	179	57.1	68	26

\* Booster Pump Capacity = 2,000 gpm

City of Madison, Wisconsin  
 East Side Water Supply Planning and Project Development  
 Task No. 8 - Well No. 15 VOC Mitigation  
 Pumping Unit Electrical Costs - **Conventional Air Strippers**

Background:

Installation of air strippers at Unit Well No. 15 will increase the total dynamic head (TDH) requirements for the well pump. The increase in TDH is a result of dynamic losses (pipe modifications) and the additional static head. This spreadsheet calculates the additional operating cost (electrical) associated with the increase in TDH.

Assumptions:

Flow Rate =	2,050	gpm	Cells w/ Inputs	
Wire-to-Water Eff =	79	percent		
Power Cost =	0.06	\$/kw		
Static Head =	25	feet		(Distance between pump discharge & aerator influent pipe)
Pipe Dia. =	18	inches		
k - Factor =	4			

Calculated Values:

Pipe Velocity =	2.6	ft./sec.	Calculated Values (Friction losses assumed to be negligent)
Dynamic Losses =	0.4	feet	
TDH (static + dynamic) =	25.4	feet	
Power Consumption (Hp) =	16.7	Hp	
Power Consumption (kw) =	12.4	kw	
Annual Power Cost =	\$ 6,536.64		
20-year Present Value Cost =	\$ 88,832.93		

# LOW Profile Air Stripper

## PUMP DATA SHEET Turbine 60 Hz

Company: Water Well Solutions  
 Name:  
 Date: 05/07/09

# UW #15 Well Pump



### Pump:

Size: 14RJHC (2 stages)  
 Type: Lineshaft  
 Synch speed: 1800 rpm  
 Curve: E6414RCPC2  
 Specific Speeds:  
 Dimensions:  
 Vertical Turbine:

Speed: 1770 rpm  
 Dia: 8.9375 in  
 Impeller:  
 Ns: 3032  
 Nss: ---  
 Suction: --- in  
 Discharge: --- in  
 Bowl size: 13.63 in  
 Max lateral: 1 in  
 Thrust K factor: 13 lb/ft

### Search Criteria:

Flow: 2200 US gpm Head: 140 ft

### Fluid:

Water  
 SG: 1  
 Viscosity: 1.105 cP  
 NPSHa: --- ft  
 Temperature: 60 °F  
 Vapor pressure: 0.2563 psi a  
 Atm pressure: 14.7 psi a

### Motor:

Standard: NEMA  
 Enclosure: TEFC  
 Sizing criteria: Max Power on Design Curve  
 Size: 100 hp  
 Speed: 1800  
 Frame: 405T

### Pump Limits:

Temperature: 120 °F  
 Pressure: 340 psi g  
 Sphere size: 0.98 in

Power: --- hp  
 Eye area: --- in<sup>2</sup>

--- Data Point ---  
 Flow: 2200 US gpm  
 Head: 140 ft  
 Eff: 84.4%  
 Power: 92.2 hp  
 NPSHr: 31.9 ft

--- Design Curve ---  
 Shutoff Head: 190 ft  
 Shutoff dP: 82.2 psi  
 Min Flow: --- US gpm  
 BEP: 84.7% eff  
 @ 2135 US gpm  
 NOL Pwr: 94.7 hp  
 @ 2609 US gpm

--- Max Curve ---  
 Max Pwr: 118 hp  
 @ 2820 US gpm

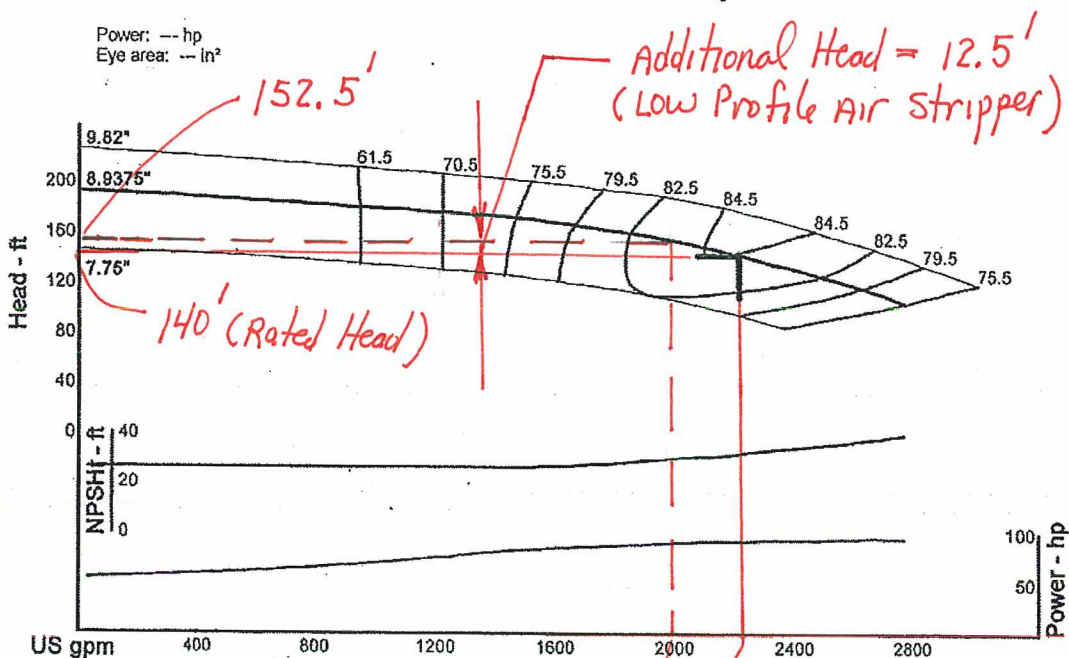

Rated Capacity:  
 2,200 gpm (3.16 mgd)  
 2,000 gpm (2.88 mgd)

### Performance Evaluation:

Flow US gpm	Speed rpm	Head ft	Pump %eff	Power hp	NPSHr ft
2640	1770	112	78.6	94.6	37.5
2200	1770	140	84.4	92.2	31.9
1760	1770	160	81.2	87.6	27.5
1320	1770	172	72.6	78.5	26
880	1770	179	57.1	68	26

\* Booster Pump Capacity = 2,000 gpm

City of Madison, Wisconsin  
 East Side Water Supply Planning and Project Development  
 Task No. 8 - Well No. 15 VOC Mitigation  
 Pumping Unit Electrical Costs - Low Profile Air Strippers

Background:

Installation of air strippers at Unit Well No. 15 will increase the total dynamic head (TDH) requirements for the well pump. The increase in TDH is a result of dynamic losses (pipe modifications) and the additional static head. This spreadsheet calculates the additional operating cost (electrical) associated with the increase in TDH.

Assumptions:

Flow Rate =	2,200	gpm	Cells w/ Inputs	
Wire-to-Water Eff =	80	percent		
Power Cost =	0.07	\$/kw		
Static Head =	12	feet		(Distance between pump discharge & aerator influent pipe)
Pipe Dia. =	18	inches		
k - Factor =	4			

Calculated Values:

Pipe Velocity =	2.8	ft./sec.	Calculated Values
Dynamic Losses =	0.5	feet	
TDH (static + dynamic) =	12.5	feet	
Power Consumption (Hp) =	8.7	Hp	
Power Consumption (kw) =	6.5	kw	
Annual Power Cost =	\$ 3,967.89		
20-year Present Value Cost =	\$ 53,923.69		



## **APPENDIX C**

### **Conceptual Opinion of Probable Construction Cost**

DRAFT



**BLACK & VEATCH**  
Corporation

8400 Ward Parkway, P.O. Box 8405, Kansas City, Missouri 64114, (913) 458-2000

B&V Project 169092.0800

**Conceptual**

**MADISON, WISCONSIN**

**EAST SIDE WATER  
SUPPLY PLANNING & PROJECT DEVELOPMENT**

**UNIT WELL NO. 15  
CONVENTIONAL AIR STRIPPER BUILDING**

**OPINION OF  
PROBABLE CONSTRUCTION COST  
January 18, 2011**

**SUMMARY**

General Requirements		\$56,200
Sitework		56,800
Conventional Air Stripper Building		568,000
Contingencies	25%	170,250
Mid-Point of Construction (Construction Period 6 Months)		8,390
Rate = %	4.0%	
Time = Years	0.25	
<b>TOTAL PROBABLE CONSTRUCTION COST (Based On Bid Date January, 2011)</b>		<b>\$859,640</b>

**BLACK & VEATCH**

Madison, Wisconsin  
 Ease Side Water Supply P&P D  
 Well No. 15 Conventional Air Stripper Building  
 Probable Construction Cost  
 January 18, 2011

<u>Item Description</u>	<u>Quantity</u>	<u>Unit</u>	<u>Unit Cost</u> \$	<u>Total Cost</u> \$
<b>GENERAL REQUIREMENTS</b>				
Mobilization		Lump Sum		10,000
Supervision		Lump Sum		31,200
Temporary facilities		Lump Sum		7,500
Temporary utilities		Lump Sum		5,000
Equipment rental & misc.		Lump Sum		2,500
Total - General Requirements				\$56,200

**CONVENTIONAL AIR STRIPPER BUILDING**

<b>Earthwork</b>				
Structural excavation	290	cu yd	20.00	5,800
Compacted fill	73	cu yd	25.00	1,833
Granular fill	12	cu yd	45.00	542
<b>Concrete, cast in place</b>				
Slab on grade/footings	53	cu yd	500.00	26,407
Walls	31	cu yd	770.00	23,884
Equipment Pad	4	cu yd	650.00	2,287
Embedded accessories		Lump Sum		2,621
<b>Masonry</b>				
Face brick	3,468	sq ft	17.00	58,956
Concrete block 12" Wall (load bearing reinforced)	3,468	sq ft	17.50	60,690
<b>Metal</b>				
Open web joists	1.6	ton	3,800.00	6,080
Metal decking	650	sq ft	4.50	2,925
Alum Grating	54	sq ft	65.00	3,510
<b>Thermal &amp; moisture protection</b>				
Single-ply roofing	650	sq ft	3.50	2,275
Cant & counterflashing	102	lin ft	40.00	4,080
Metal coping	102	lin ft	30.00	3,060
<b>Insulation</b>				
Rigid				
Roof	650	sq ft	2.50	1,625
Wall	3,468	sq ft	2.25	7,803
<b>Doors</b>				
Hollow metal	21	sq ft	150.00	3,150
Overhead sectional, 10' x 12'	1	each	9,000.00	9,000
<b>Equipment</b>				
Conventional Air Stripper w/blower	1	each	182,000.00	182,000
<b>Instrumentation</b>				Lump Sum
				10,102
<b>Mechanical</b>				
<b>HVAC &amp; Plumbing</b>				Lump Sum
				19,500
<b>Process piping</b>				

**BLACK & VEATCH**

Madison, Wisconsin  
Ease Side Water Supply P&P D  
Well No. 15 Conventional Air Stripper Building  
Probable Construction Cost  
January 18, 2011

<u>Item Description</u>	<u>Quantity</u>	<u>Unit</u>	<u>Unit Cost</u>	<u>Total Cost</u>
			\$	\$
24" Aerator Effluent	20	lin ft	720.00	14,400
18" Aerator Influent	50	lin ft	540.00	27,000
Misc. piping & valves		Lump Sum		2,070
Pipe supports		Lump Sum		1,400
Electrical		Lump Sum		85,000
				<hr/>
Total - Conventional Air Stripper Building				\$568,000



**BLACK & VEATCH**  
C o r p o r a t i o n

8400 Ward Parkway, P.O. Box 8405, Kansas City, Missouri 64114, (913) 458-2000

B&V Project 169092.0800

**Conceptual**

**MADISON, WISCONSIN**

**EAST SIDE WATER  
SUPPLY PLANNING & PROJECT DEVELOPMENT**

**UNIT WELL NO. 15  
LOW PROFILE AIR STRIPPER**

**PROBABLE CONSTRUCTION COST  
January 18, 2011**

**SUMMARY**

General Requirements		\$84,200
Sitework		85,124
Low Profile Air Stripper		851,242
Contingencies	25%	255,140
Mid-Point of Construction (Construction Period 6 Months)		12,570
Rate = %	4.0%	
Time = Years	0.25	
<b>TOTAL PROBABLE CONSTRUCTION COST (Based On Bid Date January, 2011)</b>		<b>\$1,288,277</b>

**BLACK & VEATCH**

Madison, Wisconsin  
 Ease Side Water Supply P&P D  
 Well No. 15 Low Profile Air Stripper  
 Probable Construction Cost  
 January 18, 2011

<u>Item Description</u>	<u>Quantity</u>	<u>Unit</u>	<u>Unit Cost</u> \$	<u>Total Cost</u> \$
<b>GENERAL REQUIREMENTS</b>				
Mobilization		Lump Sum		15,000
Supervision		Lump Sum		46,800
Temporary facilities		Lump Sum		11,200
Temporary utilities		Lump Sum		7,500
Equipment rental & misc.		Lump Sum		3,700
Total - General Requirements				\$84,200
<b>Low Profile Air Stripper</b>				
Earthwork				
Structural excavation	360	cu yd	20.00	7,200
Compacted fill	84	cu yd	25.00	2,100
Granular fill	15	cu yd	45.00	690
Concrete, cast in place				
Slab on grade/footings	36	cu yd	500.00	18,019
Walls	43	cu yd	770.00	33,438
Equipment Pad	14	cu yd	650.00	9,196
Embedded accessories		Lump Sum		2,808
Masonry				
Face brick	1,488	sq ft	17.00	25,296
Concrete block 12" Wall	1,488	sq ft	17.50	26,040
Metal				
Open web joists	2.1	ton	3,800.00	7,980
Metal decking	828	sq ft	4.50	3,726
Alum Grating	120	sq ft	65.00	7,800
Thermal & moisture protection				
Single-ply roofing	828	sq ft	3.50	2,898
Cant & counterflashing	118	lin ft	40.00	4,720
Metal coping	118	lin ft	30.00	3,540
Insulation				
Rigid				
Roof	828	sq ft	2.50	2,070
Wall	1,488	sq ft	2.23	3,311
Doors				
Hollow Metal	21	sq ft	150.00	3,150
Overhead sectional, 10' X 12'	4	each	9,000.00	36,000
Equipment				
Low Profile Air Stripper w/blower		Lump Sum		490,000
Instrumentation		Lump Sum		10,000
Mechanical				
Process piping				
24" Aerator Effluent	40	lin ft	720.00	28,800

**BLACK & VEATCH**

Madison, Wisconsin  
Ease Side Water Supply P&P D  
Well No. 15 Low Profile Air Stripper  
Probable Construction Cost  
January 18, 2011

<u>Item Description</u>	<u>Quantity</u>	<u>Unit</u>	<u>Unit Cost</u>	<u>Total Cost</u>
			\$	\$
18" Aerator Influent	60	lin ft	540.00	32,400
Misc. piping & valves		Lump Sum		3,060
Pipe supports		Lump Sum		2,000
Electrical		Lump Sum		85,000
				<hr/>
Total - Low Profile Air Stripper				\$851,242